

# ASSEMBLY INSTRUCTIONS

ITEM No.:HRN.KD.OT

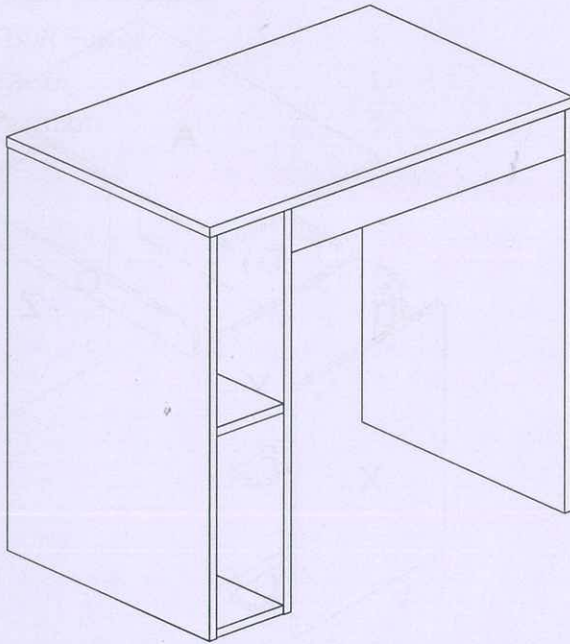



Turn clockwise to lock cam with bolt.



The arrow direction-front

Incorrect Correct

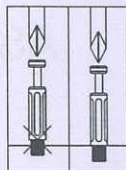

Screw cam bolts all the way in.

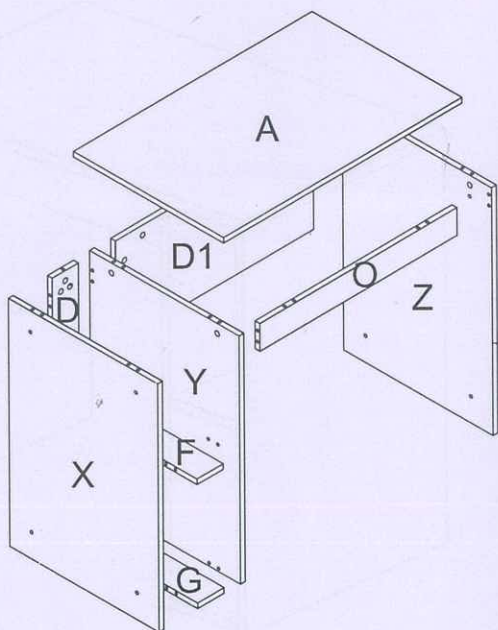

# PARTS LIST

ITEM	DESCRIPTION	QTY.
A	Top panel	1
G	Bottom panel	1
D	Back panel	1
D1	Back panel	1
X	Left side panel	1
Z	Right side panel	1
F	Fhelf Panel	1
O	Panel	1
Y	Partition	1

# PARTS LIST

ITEM	DESCRIPTION	QTY.	ITEM	DESCRIPTION	QTY.
(c1)	6*35 Cam Bolt	33	(b1)	6*30 Fix Bolt	4
(d1)	8*30 Dowel pin	26	(c3)	Cover	4
(c2)	( $\frac{5}{8}$ " ) Cam Cover	33	(s5)	Feet	6
			(a)	Wrench	1



(c1) 6\*35 Cam Bolt-33



(d1) 8\*30 Dowel Pin-26



(c2) ( $\frac{5}{8}$ " ) Cam Cover-33



(s5) Feet-6



(a) Wrench-1



(b1) 6\*30 Fix Bolt-4



(c3) Cover-4

## Pre-installed parts



(c5) Cam

# STEP 1

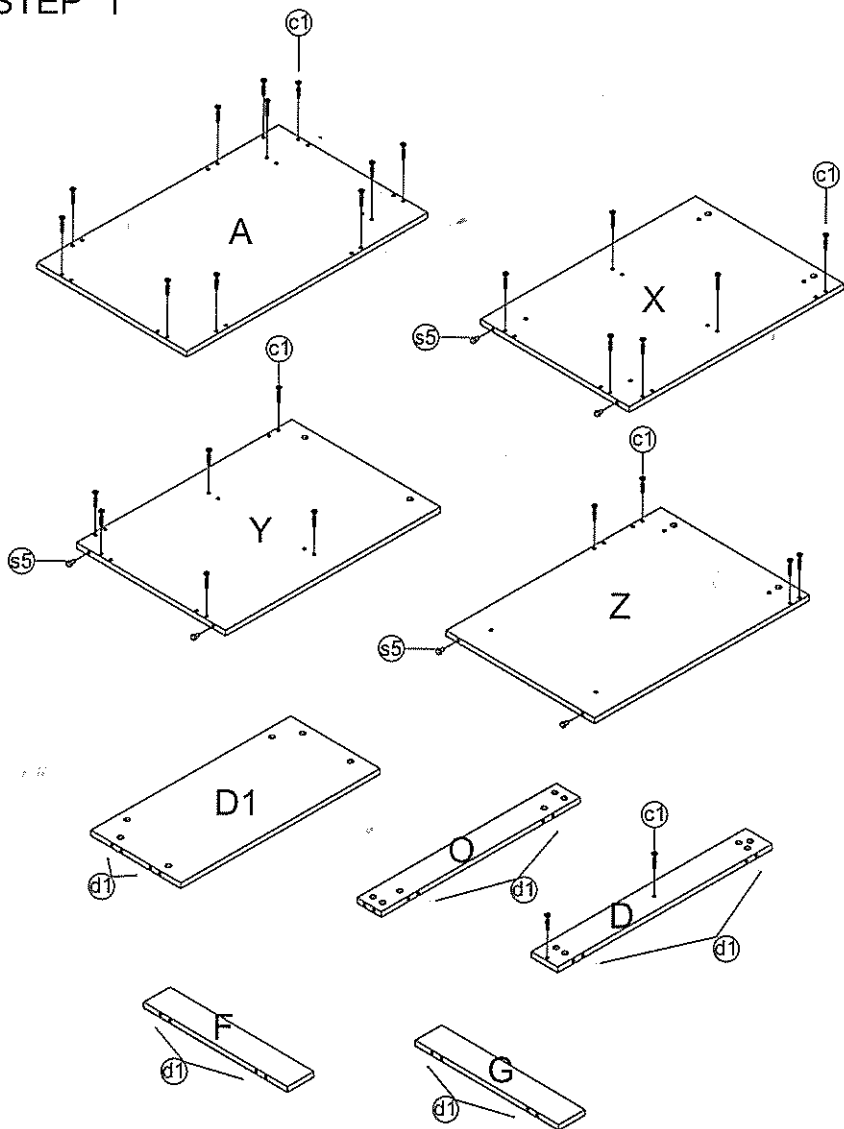

## Preparing panel A.G.X.Z.F.Y and O1.

1. Insert cam bolts (c1) into panels A.G.X.Z.D and Y as illustrated above.
2. Insert dowel pins (d1) to panels X.Z.O.F.D1.G and Y as illustrated above.
3. Insert feet pins (s5) to panels Y.X and Z as illustrated above.

## STEP 2

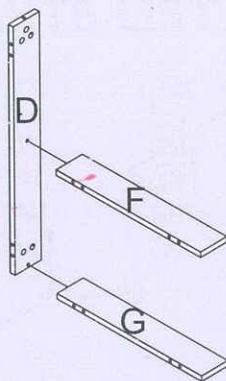

### Panel D.F and G assembly.

1. Insert cam bolts (C) on panel D and Z into cams on panels F and G and tighten in a clockwise direction as illustrated above.

## STEP 3

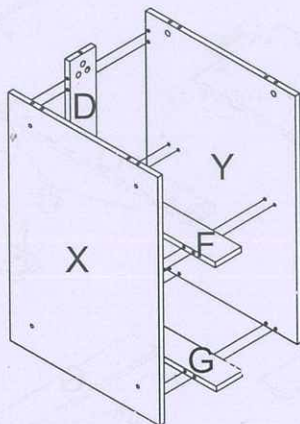

### Panel X and Y assembly.

1. Insert cam bolts (C) on panel X and Y into cams on panels D.G and F and tighten in a clockwise direction as illustrated above.

## STEP 4

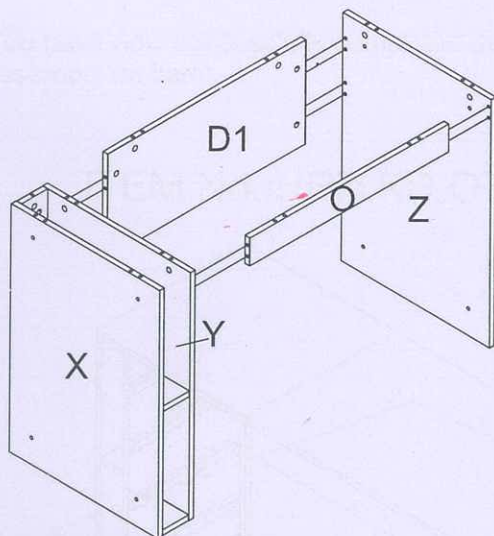

### Panel O and D1 assembly.

1. Insert cam bolts (Ⓢ) on panel Y and Z into cams on panels O and D and tighten in a clockwise direction as illustrated above.

## STEP 5

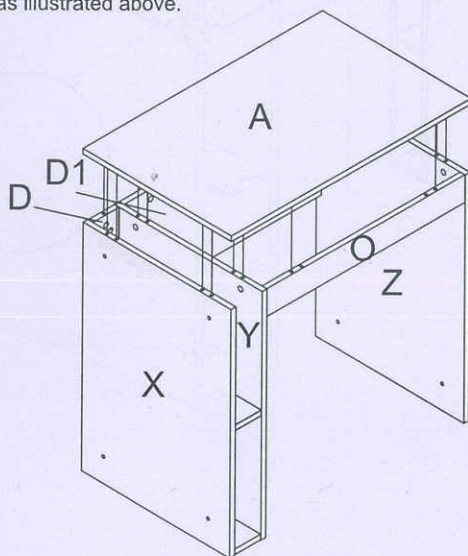

### Panel A assembly.

1. Insert cam bolts (Ⓢ) on panel A into cams on panels O.Z.X.Y.D1 and D and tighten in a clockwise direction as illustrated above.

## STEP 6

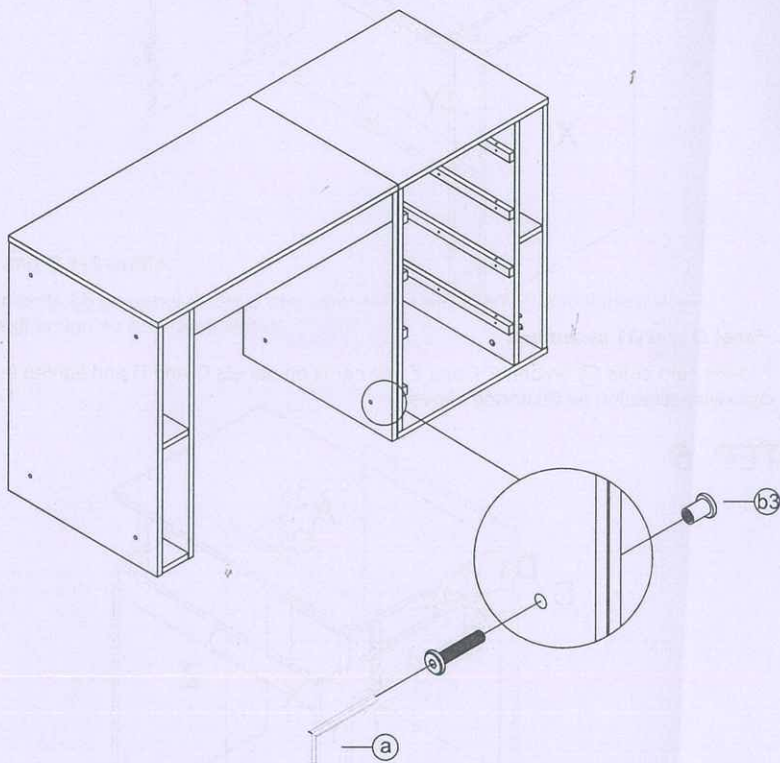

### Fix Bolt assembly.

1. Connecting Cabinet A and B is using Wrench **a** to insert and secure four Fix Bolts **b3** as illustrated above.



You have now successfully completed the assembly on item:

ITEM No.:HRN.KD.OT

