

SOVEREIGN MKIII

ASSEMBLY INSTRUCTIONS

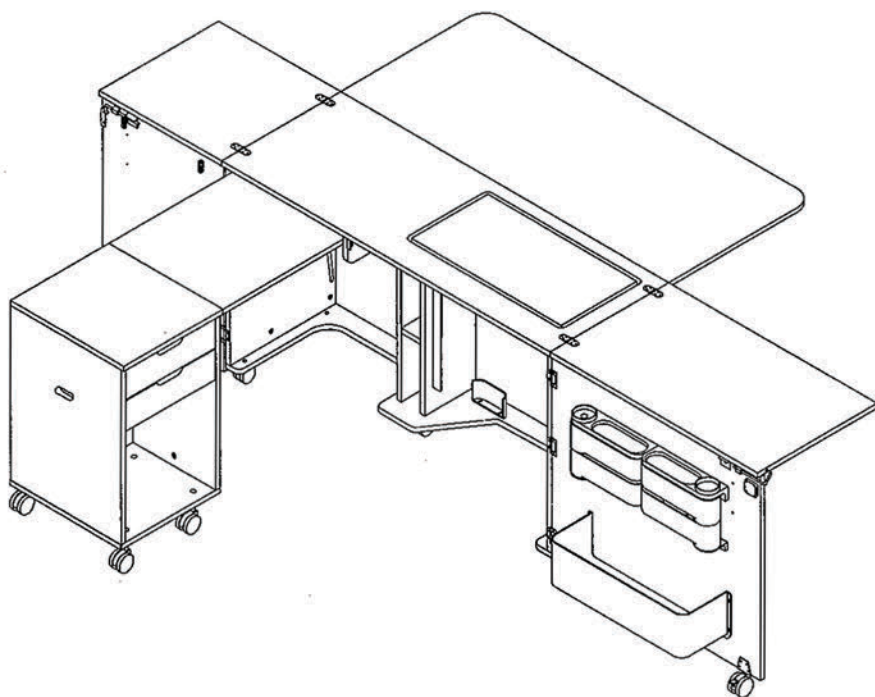

**Scan the QR code below for follow-along
video instructions on assembling your
Sovereign MKIII.**



**A power drill / screwdriver is recommended
for assembling this product, allowing for an
easier and faster build.**







































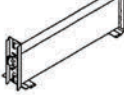

⚡ ELECTRIC LIFT OPTION

If you have chosen for the electric lift upgrade. When installing the lift, you need to follow the electric lift guide. This will be extra documentation packed inside the lifter box.

Please refrain from testing the electric lift prior to completing assembly.

Sovereign MKIII Assembly Instructions

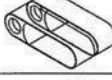
COMPONENTS	DESCRIPTION	QTY
c1 	Cam Bolt 30mm	46
c3 	Cam Ø15mm	42
c4 	Cam Ø15X10mm	4
d1 	Dowel Ø8 x 30mm	48
c2 	Cover	46
s1 	Screw Ø4x14mm CS ZP	56
s2 	Screw Ø3x14mm CS ZP	24
s3 	Screw Ø3.5x20mm CS ZP	10
s4 	Screw Ø4 x 25mm C/S	8
s5 	Screw Ø3.5 x 30mm	8
g2 	Gate Leg Button	1
g1 	Castor Washer	9
t2 	Castor Ø50	6
t1 	Castor Ø50 Lockable	2
t3 	Castor Ø50 Extension	4
r3 	Castor Spanner	1
L2 	Lock Striker	1
L1 	Lock & Key & Escutcheon	1
h3 	Butt Hinge	2
h2 	Flush Hinge (52mm)	6
h4 	Flap Hinge	3
b2 	Handle Screw	4
h1 	Bow Handle	2
d 	Door Hook (125mm)	2
	Glue Bottle	2

COMPONENTS	DESCRIPTION	QTY
	Insert Holder	1
	Lifter Rail (Right)	1
	Lifter Rail (Left)	1
	Lifter (692mm)	1
	Ramp	3
	Equalizer	2
	Door Plate	2
	Swivel Tray Bracket	2
	Door Shelf (Left)	1
	Door Shelf (Right)	1
	Large Bucket (Tinted)	1
	Swivel Tray (Ass.)	2
	Cotton Reel Insert	2
	Pin Cushion Foam	2
	Basket Insert	1

Sovereign MKIII Assembly Instructions

Sovereign MKIII panels and their descriptions

Note: Hole position helps with panel orientation

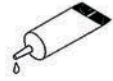

Before assembling place 2 to 3 drops of glue in each dowel hole.

Do Not place glue in Cam or Cam Bolt holes.

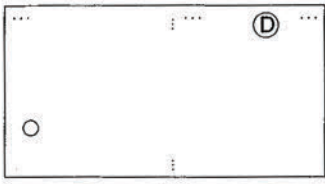

Back



Back Flap

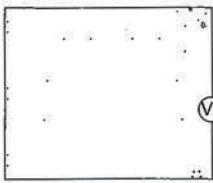

Large Door

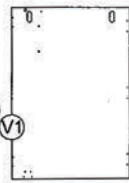

Small Door

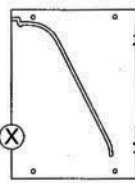

End Left



End Right

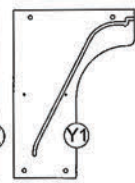

Division Large

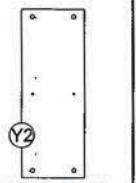

Division Small

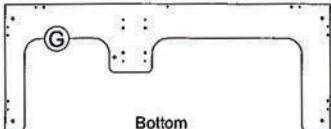

Bottom

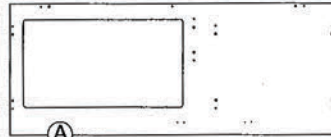

Top/Flap Assembly

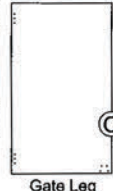

Gate Leg

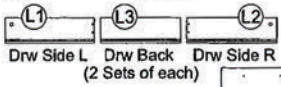

Drw Side L Drw Back Drw Side R
(2 Sets of each)

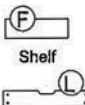

Shelf

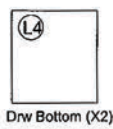

Drw Bottom (X2)



Lifter Board



Caddy Back

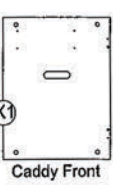

Caddy Front

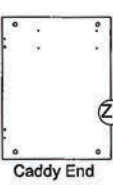

Caddy End

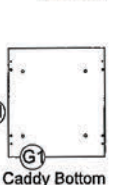

Caddy Bottom

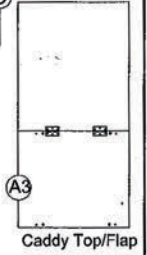

Caddy Top/Flap

1. Top / Flap Pre-Assembly



Cam Bolt (x11)



Ramp (X2)

Screw s3 Ø3.5 x 20mm (x4)

Assembly Steps

1. Screw the Cam Bolts into the Top panels as shown.
2. Fix the Ramps to the Top using Screw s3 Ø3.5 x 20mm

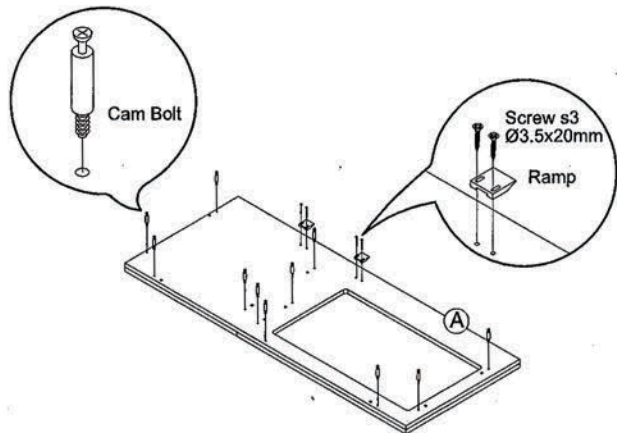

2. Bottom Pre-Assembly



Cam Bolt (x11)



Insert Holder



Screw s1 Ø4 x 14mm (x2)

Assembly Steps

1. Screw the Cam Bolts into the Bottom Panel as shown.
2. Fix Insert Holder to the Bottom using Screw s1 Ø4 x 14mm

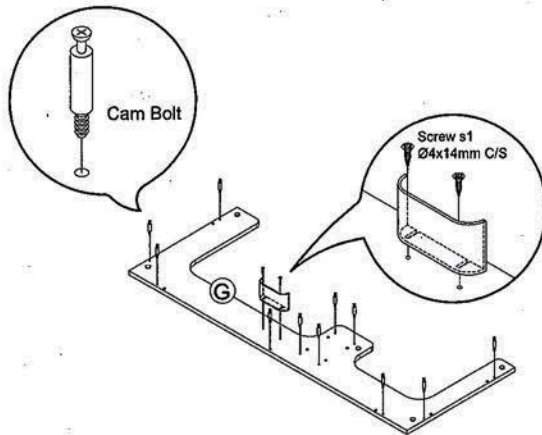

3. End Right Pre-Assembly



Dowel Ø8x30mm (x4)



Cam Ø15mm (x4)



R/H Lifter Rail



Screw s1 Ø4 x 14mm (x3)



Cam Bolt (x2)

Assembly Steps

1. Screw the Cam Bolts into the Bottom Panel as shown.
2. Place 2 to 3 drops of glue into each dowel hole and insert the Dowels.
3. Insert the Cams ensuring the arrow points to the closest edge
4. Screw R/H Lifter Rail onto End using Screw s1 Ø4x14mm

Note:

Lifter Rail will be level with the panel end.

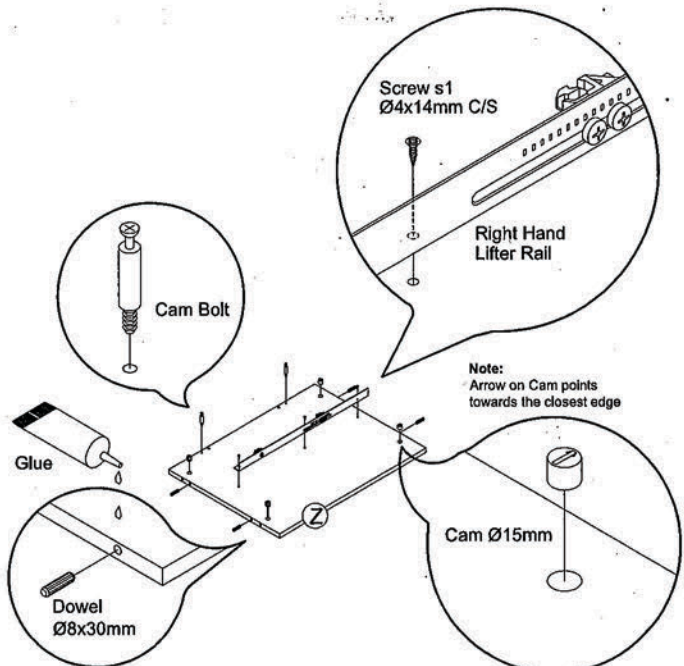

Sovereign MKIII Assembly Instructions

4. Small Division & Shelf Pre-Assembly

Dowel Ø8x30mm (x10)

L/H Lifter Rail

Screw s1 Ø4x14mm (x3)

Cam Ø15mm (x8)

Assembly Steps

1. Place Cams Into holes shown. Ensure the arrow on the Cam points to the nearest edge.
2. Insert Dowels with 2 to 3 drops of Glue into the Division dowel holes.
3. Screw on L/H Lifter Rail using Screw s1 Ø4x14mm CS
4. Insert Dowels with 2 to 3 drops of glue into the Small Shelf dowel holes

Note:

Rail will be level with panel edge

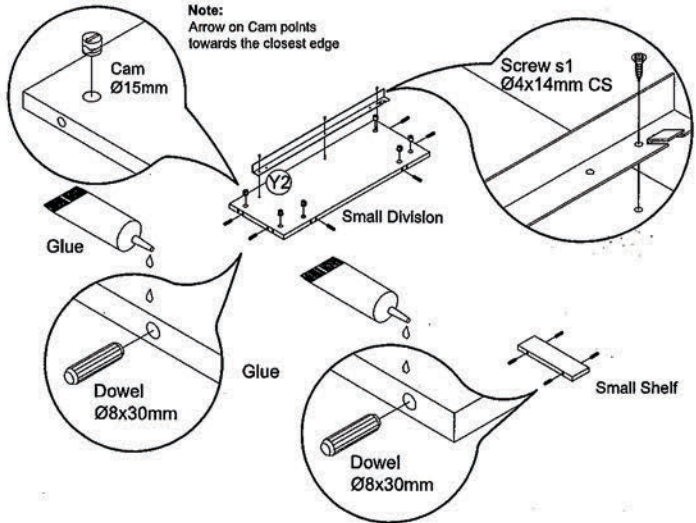

5. End Left Pre-Assembly

Dowel Ø8x30mm (x4)

Cam Ø15mm (x4)

Cam Bolt (x2)

Assembly Steps

1. Screw the Cam Bolts into the End Left Panel as shown.
2. Insert Cams ensuring the arrow points to the closest edge as shown.
3. Insert Dowels with 2 to 3 drops of Glue into holes

Note:
Arrow on Cam points towards the closest edge

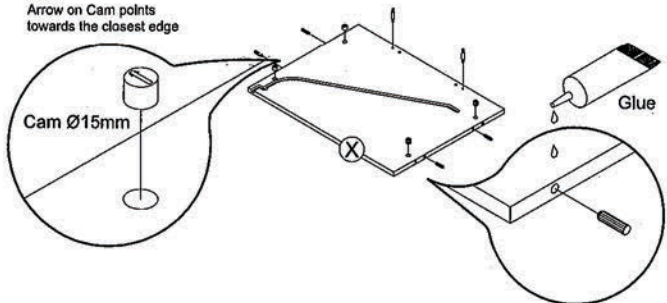

6. Large Division Pre-Assembly

Dowel Ø8x30mm (x6)

Cam Ø15mm (x6)

Lock Striker

Screw s1 Ø4x14mm (x2)

Assembly Steps

1. Insert Dowels with 2 to 3 drops of Glue in each hole.
2. Place Cams Into holes shown. Ensure the arrow on the Cam points to the nearest edge.
3. Fit the Lock Striker using Screw s1 Ø4x14mm C/S

Note:
Arrow on Cam points towards the closest edge

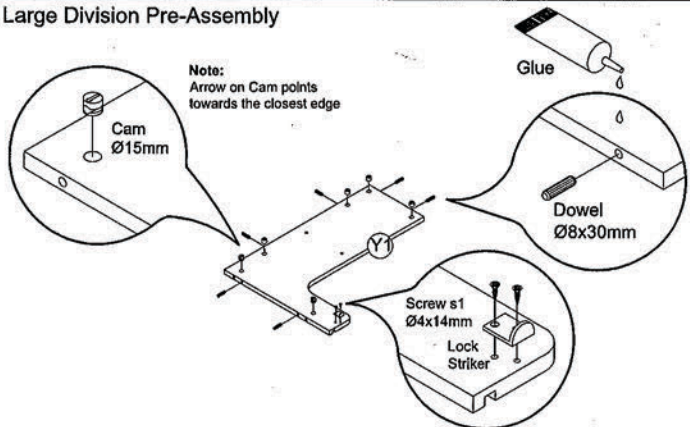

7. Back Pre-Assembly



Dowel Ø8x30mm (x8)

Cam Ø15mm (x10)

Cam Bolt (x4)

Assembly Steps

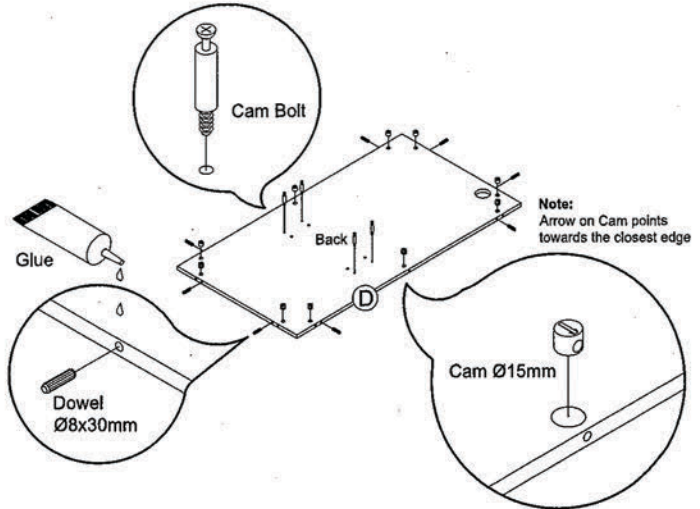
1. Screw the Cam Bolts into the Back Panel as shown.
2. Place 2 to 3 drops of glue into each dowel hole and insert the Dowels.
3. Insert the Cams ensuring the arrow points to the closest edge



8. Cabinet Assembly

Assembly Steps

1. Place 2 to 3 drops of Glue in the dowel holes of the Small Division.
2. Insert the Small Shelf into the Small Division.
3. Place 2 to 3 drops of Glue in the dowel holes of the Large Division.
4. Insert the Small Shelf into the Large Division assembly.

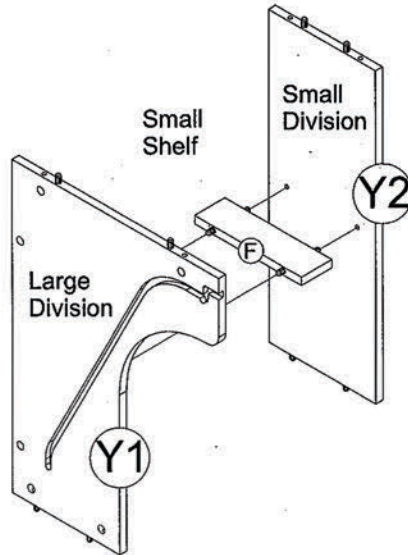

Sovereign MKIII Assembly Instructions

9. Cabinet Assembly

Assembly Steps

1. Place 2 to 3 drops of glue in the dowels holes in the Back.
2. Locate and fit the Small Shelf & Small & Large over the dowel holes in the Back & insert. Turn the Cam a half turn clockwise to secure.
3. Place 2 to 3 drops of glue in the dowels holes in the L/H End & R/H End.
4. Locate and fit the L/H End & R/H End over the dowel holes in the Back & insert. Turn the Cam a half turn clockwise to secure.

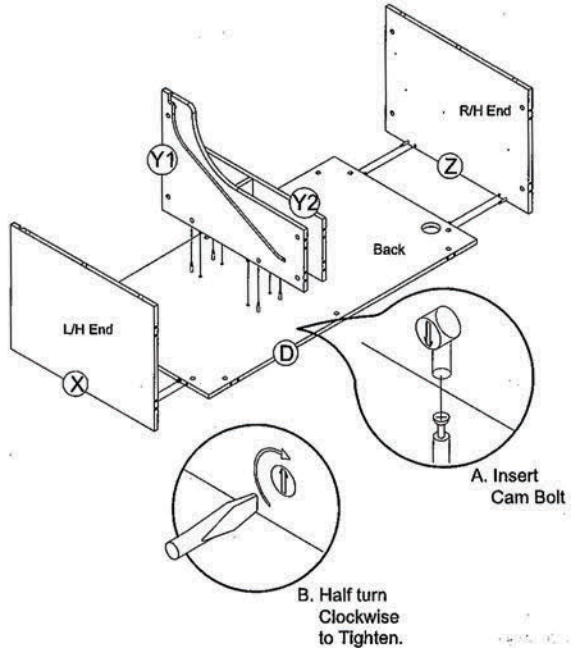

10. Cabinet Assembly

Assembly Steps

1. Place 2 to 3 drops of Glue into the dowel holes in the Bottom.
2. Position the Cam holes in the L/H End & R/H End & Large Division & Small Division & Back over the Cam Bolts in the Bottom and insert. Secure by turning the Cam a half turn clockwise.

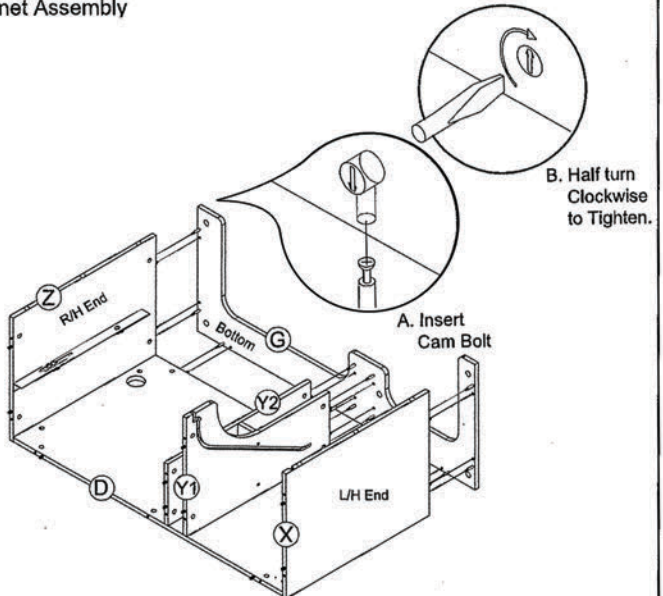

Sovereign MKIII Assembly Instructions

11. Lifter & Lifter Board Assembly

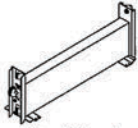

Lifter (692mm)



Screw s1 Ø4x14mm (x4)

Note: Lifter orientation on lifter board.

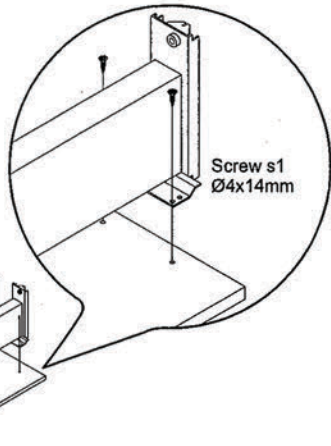
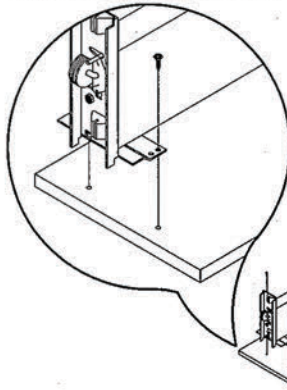

Screw s1 Ø4x14mm

Assembly Steps

1. Locate the Lifter on the Lifter Board and secure using Screw s1 Ø4x14mm CS

Note: Make sure the Lifter and Lifter Board are orientated as shown

12. Lifter Assembly into Cabinet



Lifter Board Assembly

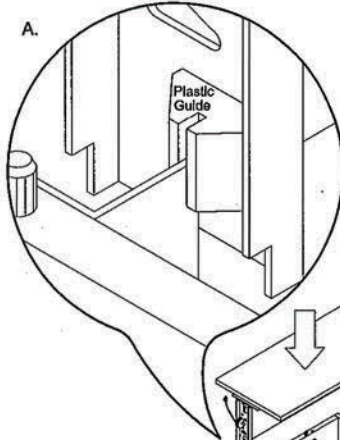

A.

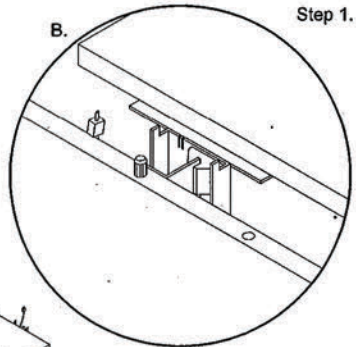

B.

Step 1.

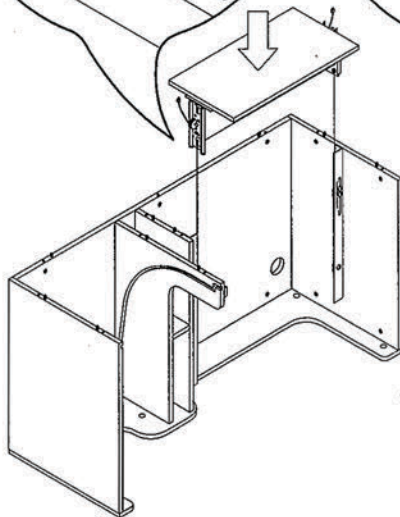

Assembly Steps

1. Position Lifter guides over Rails and gently slide the Lifter into position.

Note:

Ensure all 4 plastic guides (2 on each side) are positioned correctly over the rails. Check the orientation with the illustration.

Sovereign MKIII Assembly Instructions

13. Lifter Cable Attachment

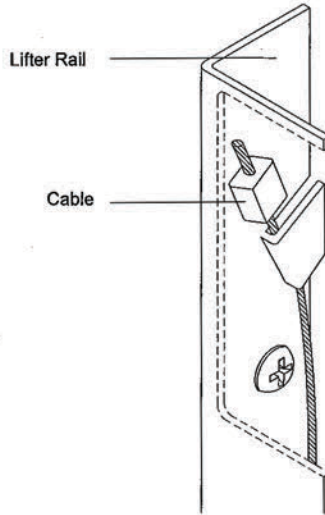

Assembly Steps

1. Loop Cable through Metal Tab on Lifter Rails and secure.
2. Push Lifter down and click into first stop position.

Note:

When the Lifter is clicked into this first stop position a small block of timber will disengage from the rear of the Lifter.

Discard block

14. Top & Cabinet Assembly

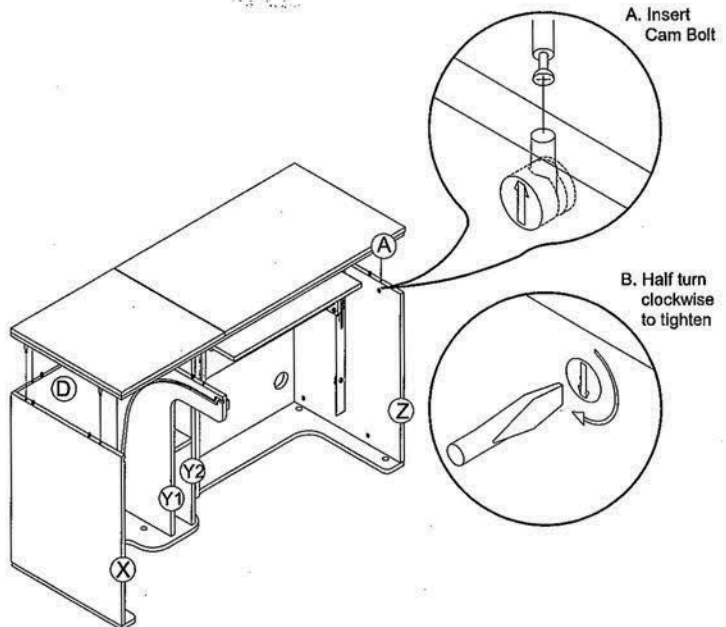

Assembly Steps

1. Place 2 to 3 drops of Glue in the Dowel holes in the Top & Flap assembly.
2. Position the Cam Bolts in the Top Panel over the Cam holes in the Ends & Division & Back and Insert. Secure by turning the Cams a half turn clockwise.
3. Rotate Cabinet onto its Back and then Top carefully

Note:

It will require 2 people to lift and rotate cabinet onto its top

15. Castor Attachment



Castor Ø50mm (x5)



Washer (x5)



Spanner

Assembly Steps

1. Place Castor Washer over Castor thread and screw into Bottom and secure using the Spanner.

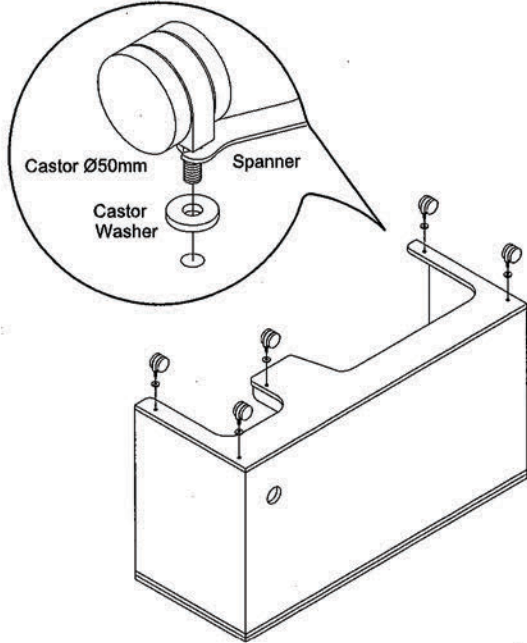

16. Gate Leg Pre-assembly



Gate Leg Button



Butt Hinge (x2)



Castor Ø50mm



Screw s1 Ø4 x 14mm (x6)

Assembly Steps

1. Tap in Gate Leg Button
2. Screw on Hinge using Screw s1 Ø4 x 14mm
3. Screw on Castor.

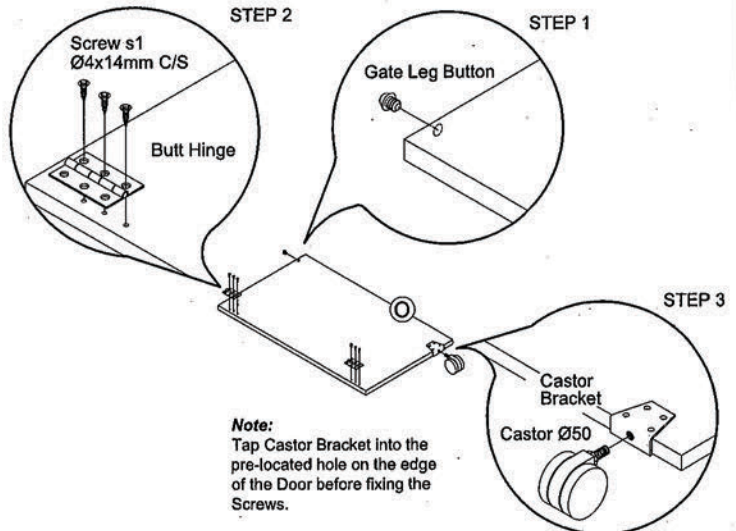

17. Gate Leg Assembly

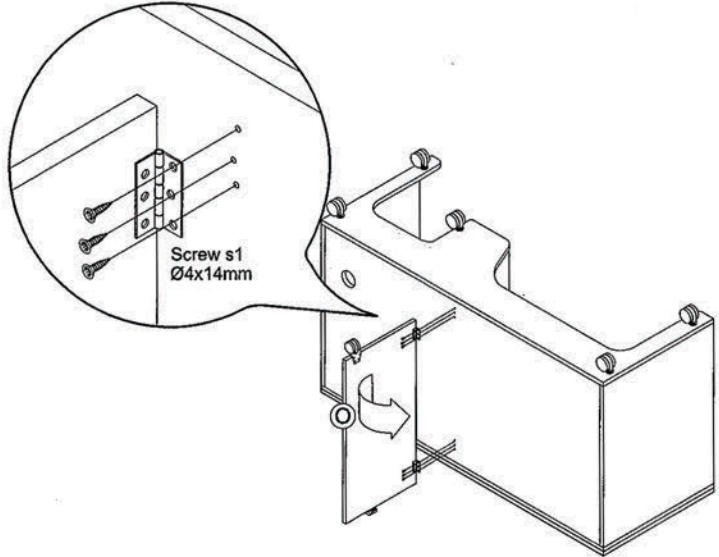

Screw s1
Ø4x14mm

Screw s1 Ø4x14mm (x6)

Assembly Steps

1. Fix Gate Leg to the back of Cabinet using Screw s1 Ø4x14mm C/S
2. Swing Gate Leg against Back
3. Roll Cabinet back over onto Castors

Note:

It will require 2 people to lift and rotate Cabinet safely.

18. Back Flap Pre-Assembly

STEP 1

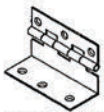

Flap Hinge (x3)



Ramp

Screw s3 Ø3.5 x 20mm (x2)

Screw s1 Ø4 x 14mm (x9)

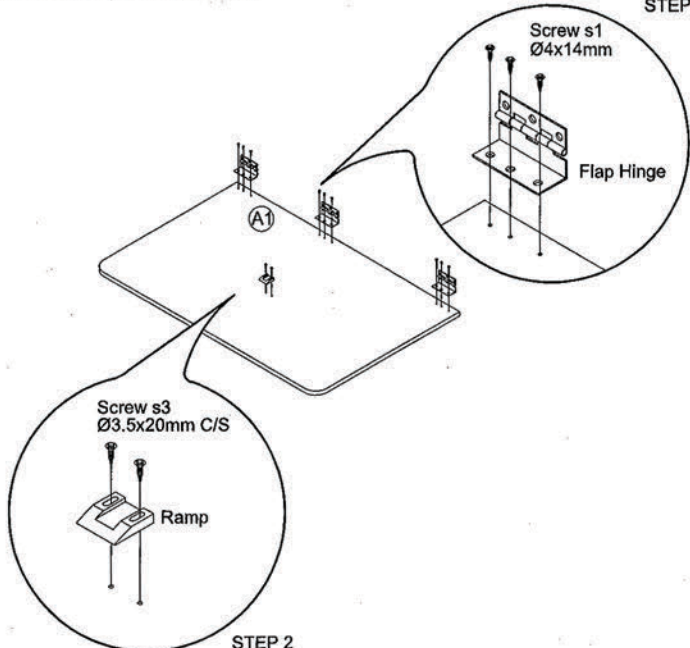

Screw s1
Ø4x14mm

Flap Hinge

Screw s3
Ø3.5x20mm C/S

Ramp

STEP 2

Assembly Steps

1. Screw on Flap Hinge using Screw s1 Ø4 x 14mm C/S
2. Screw on Ramp using Screw s3 Ø3.5 x 20mm C/S

19. Back Flap Assembly

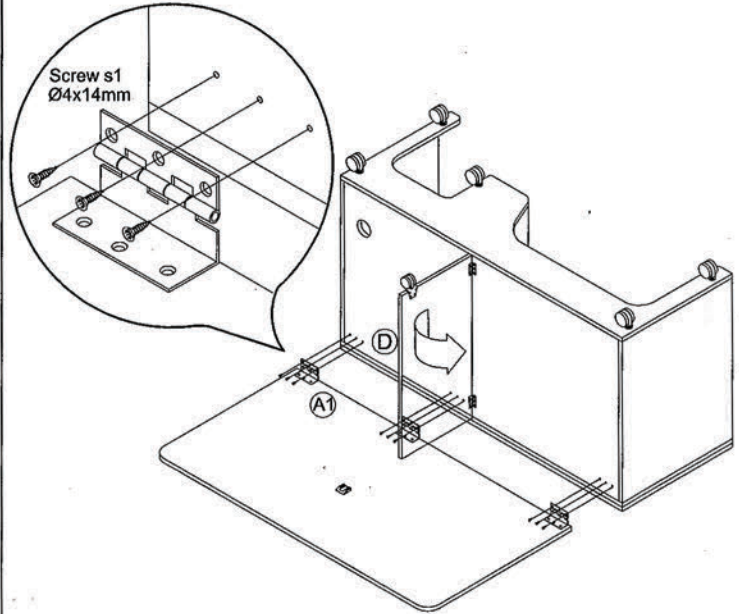

 Screw s1 Ø4x14mm (x9)

Assembly Steps

1. Fix the Back Flap to the Cabinet using Screw s1 Ø4x14mm C/S

20. Small Door Pre-assembly

 Flush Hinge 52mm (x3)

 Door Plate (x2)

 Castor Ø50mm Locking

 Door Hook (125mm)

 Screw s1 Ø4x14mm (x5)

 Screw s2 Ø3x14mm (x6)

 Equalizer

Assembly Steps

1. Screw on Flush Hinge using Screw s2 Ø3x14mm C/S
2. Screw on Castor (Locking)
3. Screw on Equalizer using Screw s1 Ø4x14mm C/S
4. Press fit Door Hook in place.
5. Screw on Door Plates using Screw s1 Ø4x14mm C/S

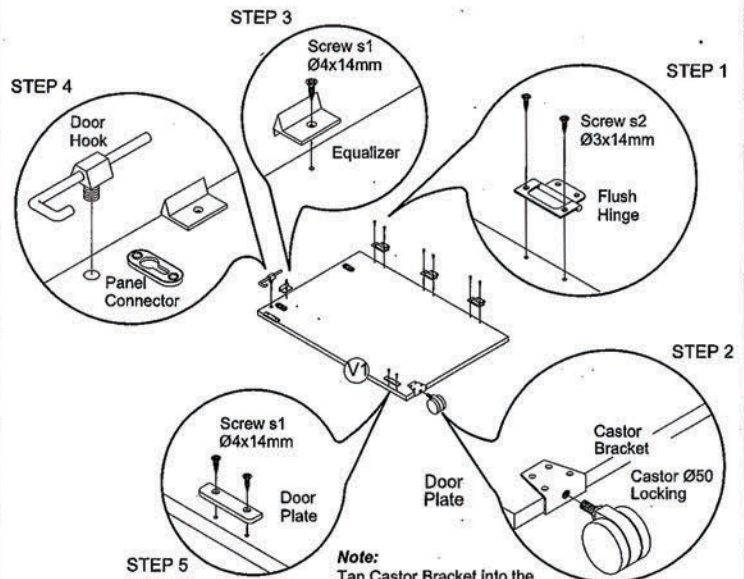

Note:
Tap Castor Bracket into the pre-located hole on the edge of the Door before fixing the Screws.

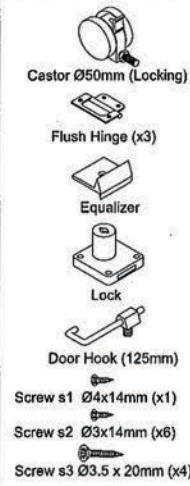

Assembly Steps

1. Screw on Flush Hinge using Screw s2 Ø3x14mm C/S
2. Screw on Castor Ø50mm
3. Screw on Equalizer using Screw s1 Ø4x14mm C/S
4. Screw on Lock using Screw s3 Ø3.5x20mm C/S
5. Press fit Door Hook in place.

21. Large Door Pre-assembly

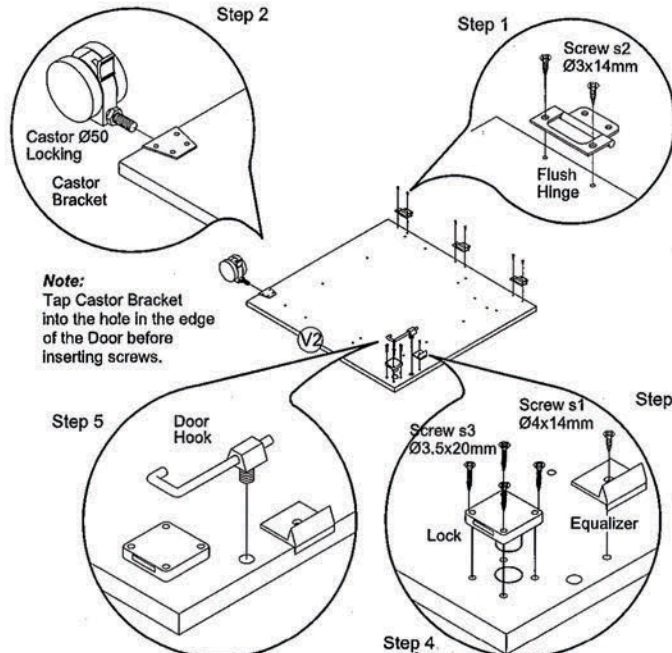

Note:
Tap Castor Bracket into the hole in the edge of the Door before inserting screws.



Assembly Steps

1. Screw on Left Hand and Right Hand Door Shelves using Screw s4 Ø4 x 25mm.

22. Large Door Shelf Assembly

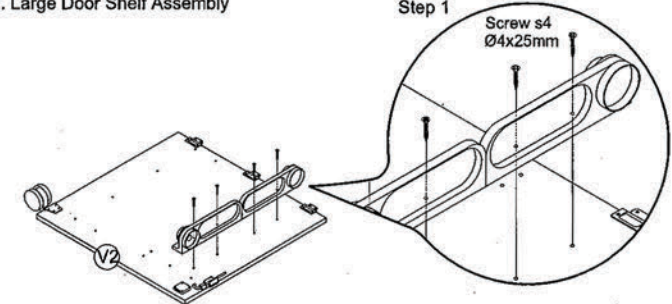



Assembly Steps

1. Insert Swivel Tray assembly into the Left Hand and Right Hand Door Shelves

23. Swivel Tray Assembly

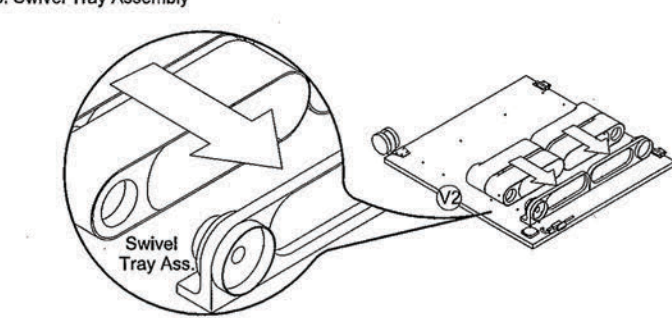

Sovereign MKIII Assembly Instructions

24. Swivel Bracket Assembly



Swivel Bracket (x2)



Screw s4 Ø4x25mm (x4)

Assembly Steps

1. Press fit the Swivel Bracket into the base of Swivel Tray assemblies and secure to the Door using Screw s4 Ø4 x 25mm

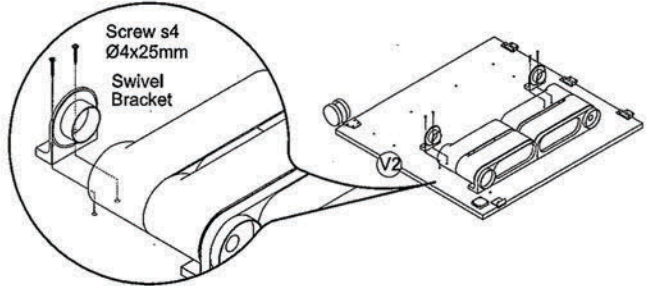

25. Large Bucket Assembly



Large Bucket



Screw s1 Ø4x14mm (x6)

Assembly Steps

1. Position the Large Bucket and secure using Screw s1 Ø4x14mm C/S

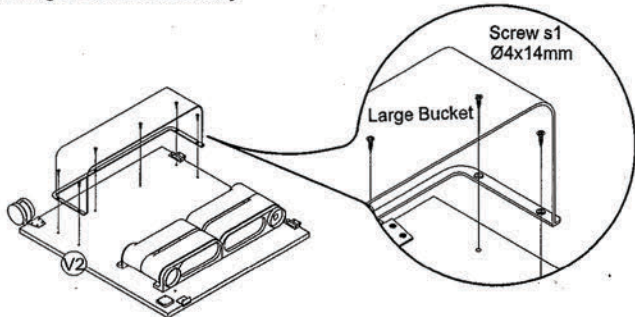

26. Small & Large Door Assembly



Screw s2 Ø3x14mm (x12)

Assembly Steps

1. Fit Small & Large Doors to Cabinet Ends using Screw s2 Ø3x14mm

Note:

Fit Screws into pre-drilled holes and secure

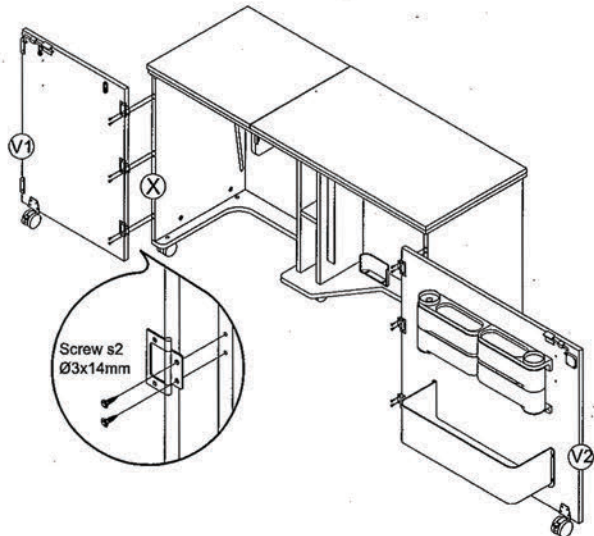

Sovereign MKIII Assembly Instructions

27. Fitting Door Handles



Bow Handle (x2)



Handle Screw (x4)



Escutcheon

Assembly Steps

1. Press the Escutcheon into the Large Door.
2. Locate and secure Handles to the Large & Small Doors using the Handle Screws supplied.

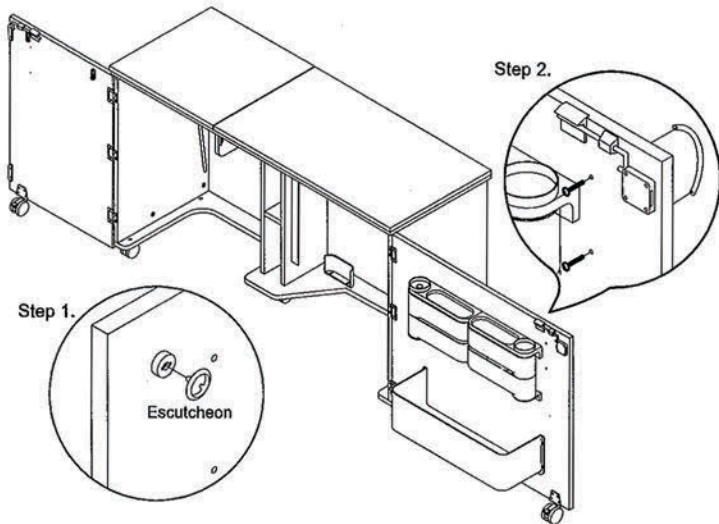

28. Securing Flaps with Door Hooks

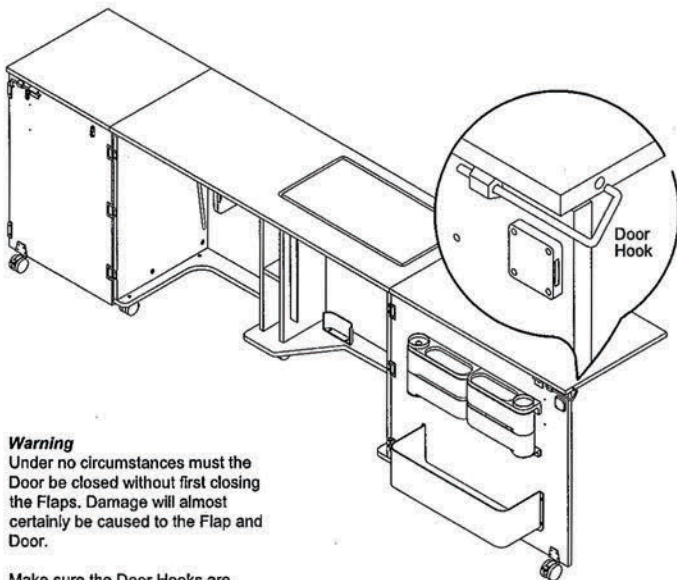

Assembly Steps

1. Open Doors and swing Flaps onto top of Doors.
2. Extend and insert the Door Hooks into the holes provided in each Flap. This will secure the Doors and Flaps.
3. Lock Castors

Note:

Doors must be open and in place before Flaps are opened and positioned on Doors.

Warning

Under no circumstances must the Door be closed without first closing the Flaps. Damage will almost certainly be caused to the Flap and Door.

Make sure the Door Hooks are engaged into the Flaps when the cabinet is open.



29. Caddy Top & Flap Pre-Assembly

Assembly Steps

1. Screw the Cam Bolts into the smaller holes in the Top panel as shown.

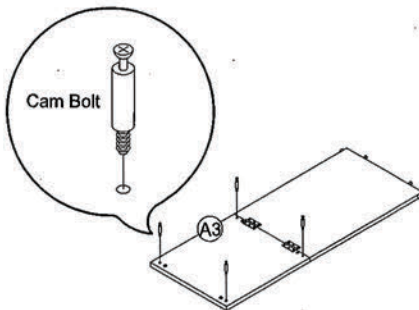

30. Caddy Ends & Back Pre-Assembly

Assembly Steps

1. Press fit Cams into the Back. Ensure the arrow on the Cams points to the nearest edge.
2. Place 2 to 3 drops of Glue in the Back holes and insert the Dowels.
3. Press fit Cams into the R/H & L/H Ends. Ensure the arrow on the Cams points to the nearest edge.
4. Place 2 to 3 drops of Glue in the dowel holes and insert the Dowels.
5. Screw the Cam Bolts into the smaller holes in the L/H End and R/H End as shown

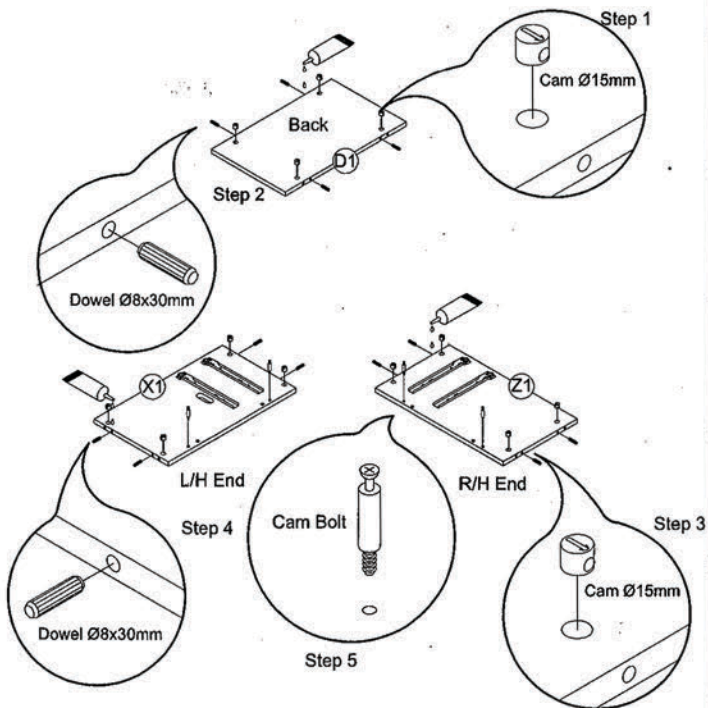



Cam Bolt (x4)

Assembly Steps

1. Screw Cam Bolts into the smaller holes in the Bottom panel as shown.

31. Caddy Bottom Pre-Assembly

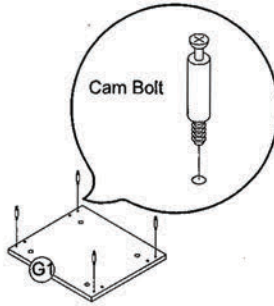

Drawer Handle

32. Caddy Assembly

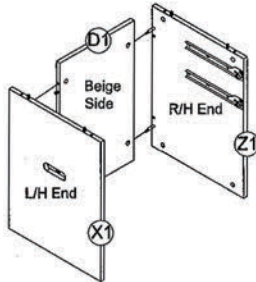

A. Insert Cam Bolt

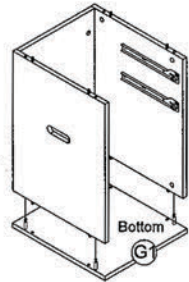



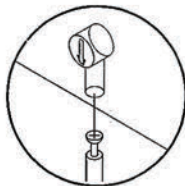

Assembly Steps

1. Place 2 to 3 drops of Glue into the dowel holes in the Bottom.
2. Locate the Cam holes in the L/H & R/H Ends over the Cam Bolts in the Bottom and insert. Secure by turning the Cam a half turn clockwise.
3. Slide the Back Into the groove located in the Ends making sure the Beige side is on the inside face.
4. Place 2 to 3 drops of Glue into the dowel holes in the Top.
5. Position the Top and Flap Assembly Cam Bolts over the the Cam holes in the Ends and insert. Secure by turning the Cam a half turn clockwise.
6. Place 4 to 5 drops of glue onto the Drawer Handle and press fit in the L/H Caddy End.

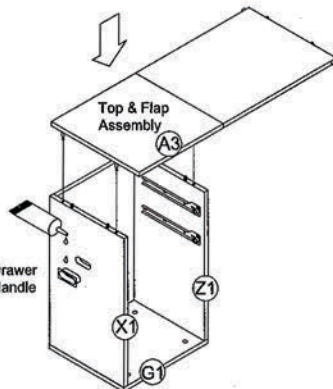
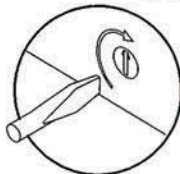

B. Half turn Clockwise to Tighten.

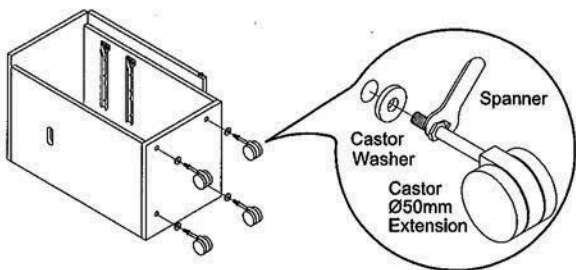
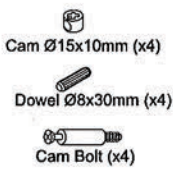
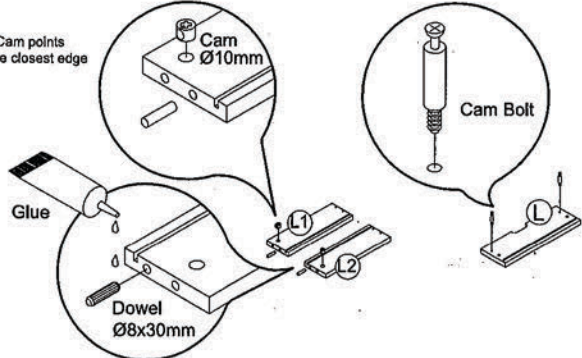

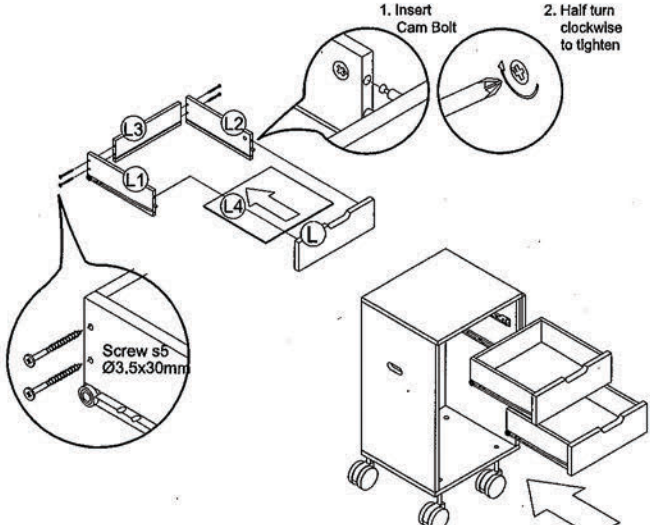
 <p>Castor Ø50 Extension (x4)</p> <p>Castor Washer (x4)</p> <p>Assembly Steps</p> <ol style="list-style-type: none"> 1. Rotate the Caddy onto its back. This may require 2 people to perform safely. 2. Place Castor Washer over the Castor thread and screw into Caddy Bottom. Secure using the Spanner. 	<h3>33. Caddy Castor Assembly</h3> 
 <p>Cam Ø15x10mm (x4)</p> <p>Dowel Ø8x30mm (x4)</p> <p>Cam Bolt (x4)</p> <p>Assembly Steps</p> <ol style="list-style-type: none"> 1. Place 2 to 3 drops of glue in each dowel hole in the Drawer Sides and insert Dowels. 2. Screw the Cam Bolts into the Drawer Front as shown. 3. Insert Cams into the Drawer Sides ensuring the arrow points to the front edge. 	<h3>34. Caddy Drawer Pre-Assembly</h3> <p>Note: Arrow on Cam points towards the closest edge</p> 
 <p>Screw s5 Ø3.5x30mm (x8)</p> <p>Assembly Steps</p> <ol style="list-style-type: none"> 1. Secure the L/H & R/H Drawer Sides to the Drawer Back using Screw s5 Ø3.5x30mm 2. Slide the Drawer Bottom into the Drawer Side groove. 3. Locate the Drawer Front and secure by turning the Cam a half turn clockwise. 4. Locate the Drawers on the runners and slide into the Caddy. 	<h3>35. Caddy Drawer Assembly</h3>  <ol style="list-style-type: none"> 1. Insert Cam Bolt 2. Half turn clockwise to tighten

36. Fitting the Caddy

Assembly Steps

1. Position the Caddy in front of the cabinet and carefully lift the Caddy Flap. Locate the Caddy Flap Rollers in the groove in the L/H End and Division and gently slide the Caddy into the cabinet.

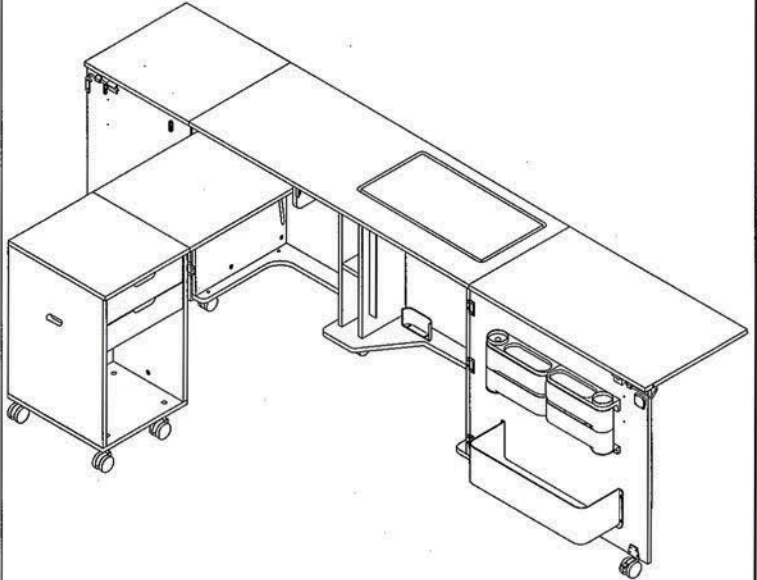

37. Fitting the Caddy to Door

Assembly Steps

1. Ensure the door is open with the cabinet flap secured with the Door Hook and the Castor locked.
2. Position the Caddy in front of the Small Door and carefully lift the Caddy Flap. Locate the screws in the Caddy Flap End into the Panel Connector and gently press down to secure. Ensure both screws and panel connects are engaged.

